

Louisville Warehouse Space for Sublease

1501 EMPIRE ROAD | LOUISVILLE, CO 80027

Size: 2,491 SF

Rate: \$22/SF Gross

Zoning: Industrial

Available: Now



A LIFE OF ADVENTURE

We wracked our brains trying to think of something you COULDN'T do with this warehouse space, and we came up short. Talk about versatility... and in great company too. This separate, secured sublease shares a building with no other than (drumroll please) Avid4 Adventure! You know, the cool kids with the summer camps. So, be prepared to get excited because adventure awaits just steps from downtown Louisville.

PROPERTY HIGHLIGHTS

- Share with an amazing B Corp- Avid4 Adventure
- Six OH doors
- Ample onsite parking with gate access
- Shared kitchenette and restrooms
- Great Access to Downtown Louisville and trails



[CLICK HERE](#)
for virtual tour



LEARN MORE ABOUT THIS PROPERTY
MarketRealEstate.com

6 DRIVE-IN OVERHEAD DOORS

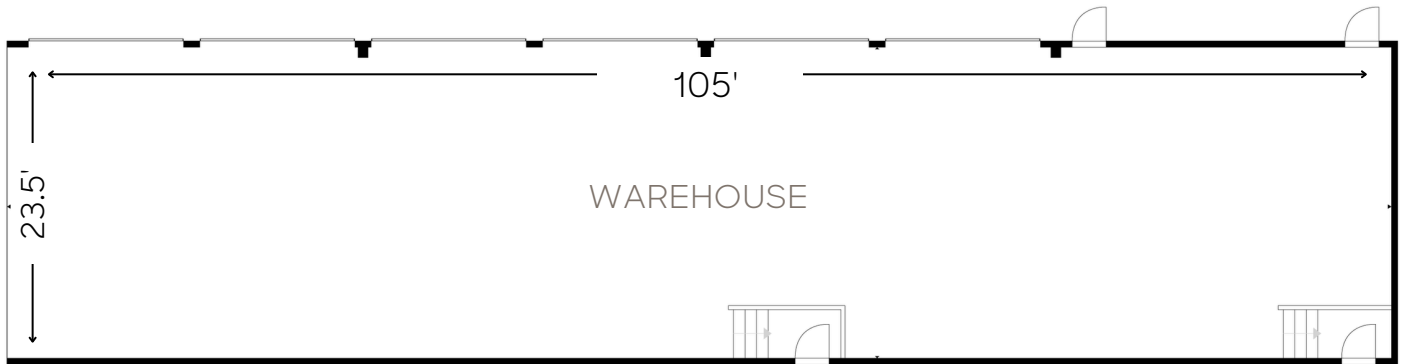

[CLICK HERE](#)
for virtual tour

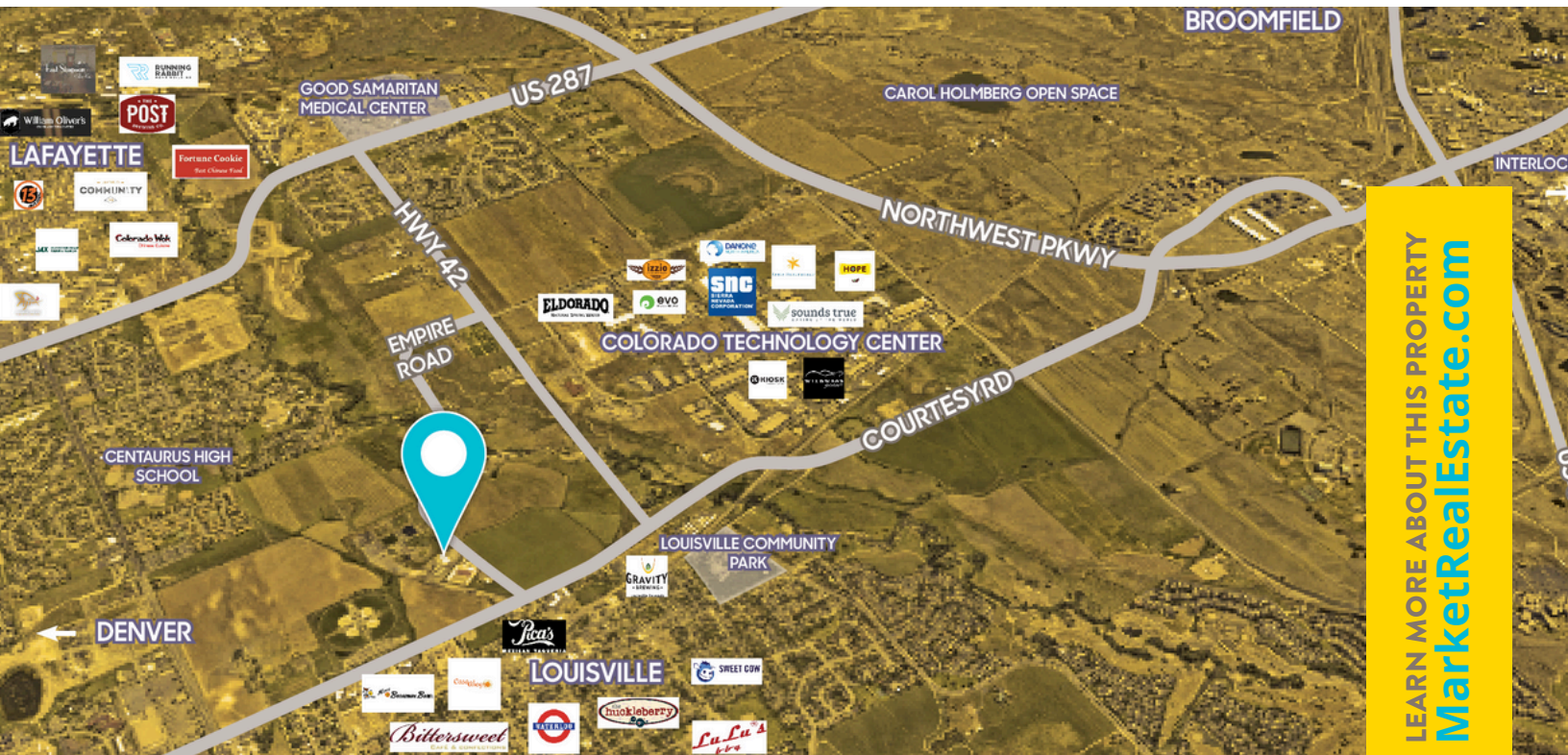

LEARN MORE ABOUT THIS PROPERTY
MarketRealEstate.com

RACHEL ROHRIG
303 444 4910
Rachel@MarketRealEstate.com

BRITTANY BOUDREAU
303 444 0566
Brittany@MarketRealEstate.com

